

Visible cam hinge fixed fulcrum

For door weights up to 9kg

Applications

Built in oven
Cooker

Geometry

Footprint: W, H, L
Fulcrum position (respect to the base): X, Y
Parallel dimension (between base and receiver): Q

Technical features

Options for fulcrum position and parallel dimension

- a. Fulcrum position X=15.5mm Y=4.5mm
Fulcrum position Q: 8mm
- b. Fulcrum position X=16mm Y=6mm
Fulcrum position Q: 12.5mm
- c. Fulcrum position X=18mm Y=6.5mm
Fulcrum position Q: 8mm
- d. Fulcrum position X=15.5mm Y=6mm
Fulcrum position Q: 9mm

Footprint H: 24.5mm
Fixing: front or top

Functionality

Balancing: 0°-88°
Closing force: 30-70N based on application and customer needs
Broil position: available

Removability

By means of a releasing hook

Performance

Operating temperature: 130°C
Dynamic test: up to 15.000 cycles

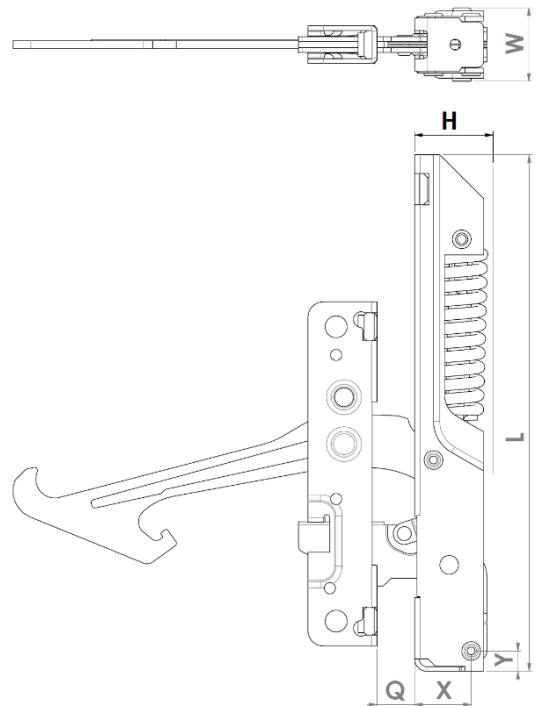

Compliance

Compliant to VDE anti pinching

Receiver

Hole fixation spacing: 94 or 91mm
Roller: steel or composite material based on customer needs

2D Drawing

✓
The following drawing shows the main functional dimensions.
Possibility of customized designs based on customer needs

